



Austrian Institute of Construction Engineering
 Schenkenstrasse 4 | T+43 1 533 65 50
 1010 Vienna | Austria | F+43 1 533 64 23
 www.oib.or.at | mail@oib.or.at



European Technical Assessment

ETA-16/0055
of 16.10.2020

General part

Technical Assessment Body issuing the European Technical Assessment

Österreichisches Institut für Bautechnik (OIB)
Austrian Institute of Construction Engineering

Trade name of the construction product

RadiusHolz

Product family to which the construction product belongs

Solid wood slab elements to be used as structural elements in buildings

Manufacturer

Holzbau Unterrainer
Schlaitenstraße 2
9951 Ainet
Austria

Manufacturing plant

Holzbau Unterrainer
Schlaitenstraße 2
9951 Ainet
Austria

This European Technical Assessment contains

16 pages including 4 Annexes which form an integral part of this assessment.

This European Technical Assessment is issued in accordance with Regulation (EU) No 305/2011, on the basis of

European Assessment Document (EAD)
130005-00-0304 "Solid wood slab element to be used as a structural element in buildings".

This European Technical Assessment replaces

European Technical Assessment ETA-16/0055 of 15.03.2016.

Remarks

Translations of this European Technical Assessment in other languages shall fully correspond to the original issued document and should be identified as such.

Communication of this European Technical Assessment, including transmission by electronic means, shall be in full. However, partial reproduction may be made with the written consent of Austrian Institute of Construction Engineering. Any partial reproduction has to be identified as such.

Specific parts

1 Technical description of the product

1.1 RadiusHolz

This European Technical Assessment (ETA) ¹ applies to the cross laminated timber "RadiusHolz". RadiusHolz is made of softwood boards which are bonded together in order to form plane and curved cross laminated timber. Generally, adjacent layers of the softwood boards are arranged perpendicular (angle of 90°) to each other, see Annex 1, Figure 1.

The principle structure of the cross laminated timber is shown in Annex 1, Figure 1 to Figure 3. Surfaces are planned.

The solid wood slab elements consist of at least three and up to eleven adjacent layers which are arranged perpendicular to each other. With regard to the thickness of the cross laminated timber, thickness and orientation of individual layers are symmetrically assembled.

RadiusHolz and the boards for its manufacturing correspond to the specifications given in the Annexes 1 and 2. The material characteristics, dimensions and tolerances of RadiusHolz, not indicated in these Annexes, are given in the technical file² of the European Technical Assessment.

The application of wood preservatives and flame retardants is not subject of the European Technical Assessment.

1.2 Components

1.2.1 Boards

The specification of the boards is given in Annex 2, Table 2. Boards are visually or machine strength graded. Only technically dried wood shall be used.

Wood species is European spruce or equivalent softwood.

1.2.2 Adhesive

The adhesive for bonding RadiusHolz shall conform to EN 301 or EN 15425.

Normally, a PU adhesive is used.

¹ In 2016 ETA-16/0055 was firstly issued as European Technical Assessment ETA-16/0055 of 15.03.2016 and amended to ETA-16/0055 of 16.10.2020.

² The technical file of the European Technical Assessment is deposited at Österreichisches Institut für Bautechnik and, in so far as is relevant to the tasks of the notified product certification body involved in the assessment and verification of constancy of performance procedure, is handed over to the notified product certification body.

2.3 Assumed working life

The provisions made in the European Technical Assessment (ETA) are based on an assumed intended working life of RadiusHolz of 50 years, when installed in the works, provided that the cross laminated timber elements are subject to appropriate installation, use and maintenance (see Clause 2.2). These provisions are based upon the current state of the art and the available knowledge and experience⁴.

The indications given as to the working life of the construction product cannot be interpreted as a guarantee neither given by the product manufacturer or his representative nor by EOTA nor by the Technical Assessment Body, but are regarded only as a means for choosing the appropriate products in relation to the expected economically reasonable working life of the works.

3 Performance of the product and reference to the methods used for its assessment

3.1 Essential characteristics of the product

Table 1: Essential characteristics of the product and product performance

No	Essential characteristic	Product performance
Basic Works Requirement 1: Mechanical resistance and stability ¹⁾		
1	Bending ²⁾	Annex 2
2	Tension and compression ²⁾	Annex 2
3	Shear ²⁾	Annex 2
4	Embedment strength	Annex 2
5	Creep and duration of the load	Annex 2
6	Dimensional stability	Annex 2
7	In-service environment	Annex 2
8	Bond integrity	Annex 2
Basic Works Requirement 2: Safety in case of fire		
9	Reaction to fire	Annex 2
10	Resistance to fire	No performance assessed
Basic Works Requirement 3: Hygiene, health and the environment		
11	Content, emission and/or release of dangerous substances	3.1.1
12	Water vapour permeability – Water vapour transmission	Annex 2
Basic Works Requirement 4: Safety and accessibility in use		
13	Impact resistance	Annex 2
Basic Works Requirement 5: Protection against noise		
14	Airborne sound insulation	No performance assessed
15	Impact sound insulation	No performance assessed
16	Sound absorption	No performance assessed

⁴ The real working life of a product incorporated in a specific works depends on the environmental conditions to which that works is subject, as well as on the particular conditions of the design, execution, use and maintenance of that works. Therefore, it cannot be excluded that in certain cases the real working life of the product can also be shorter than the assumed working life.

Basic Works Requirement 6: Energy economy and heat retention		
17	Thermal conductivity	Annex 2
18	Air permeability	No performance assessed
19	Thermal inertia	Annex 2
1) These characteristics also relate to BWR 4.		
2) Load bearing capacity and stiffness regarding mechanical actions perpendicular to and in plane of the solid wood slab element.		

3.1.1 Hygiene, health and the environment

The release of dangerous substances is determined according to EAD 130005-00-0304, "Solid wood slab element to be used as a structural element in buildings". No dangerous substances is the performance of the RadiusHolz in this respect.

NOTE: In addition to the specific clauses relating to dangerous substances contained in the European Technical Assessment, there may be other requirements applicable to the products falling within its scope (e.g. transposed European legislation and national laws, regulations and administrative provisions). In order to meet the provisions of the Construction Products Regulation, these requirements need also to be complied with, when and where they apply.

3.2 Assessment methods

3.2.1 General

The assessment of the essential characteristics in Clause 3.1 of RadiusHolz for the intended use, and in relation to the requirements for mechanical resistance and stability, for safety in case of fire, for hygiene, health and the environment, for safety and accessibility in use and for energy economy and heat retention in use in the sense of the basic requirements for construction works № 1, 2, 3, 4 and 6 of Regulation (EU) № 305/2011 has been made in accordance with the European Assessment Document EAD 130005-00-0304, Solid wood slab element to be used as a structural element in buildings.

3.2.2 Identification

The European Technical Assessment for RadiusHolz is issued on the basis of agreed data that identify the assessed product. Changes to materials, to composition, to characteristics of the product, or to the production process could result in these deposited data being incorrect. Österreichisches Institut für Bautechnik should be notified before the changes are implemented, as an amendment of the European Technical Assessment is possibly necessary.

4 Assessment and verification of constancy of performance (thereafter AVCP) system applied, with reference to its legal base

4.1 System of assessment and verification of constancy of performance

According to Commission Decision 97/176/EC the system of assessment and verification of constancy of performance to be applied to RadiusHolz is System 1. System 1 is detailed in Commission Delegated Regulation (EU) № 568/2014 of 18 February 2014, Annex, 1.2., and provides for the following items

- (a) The manufacturer shall carry out
 - (i) factory production control;
 - (ii) further testing of samples taken at the manufacturing plant by the manufacturer in accordance with a prescribed test plan⁵;
- (b) The notified product certification body shall decide on the issuing, restriction, suspension or withdrawal of the certificate of constancy of performance of the construction product on the basis of the outcome of the following assessments and verifications carried out by that body:
 - (i) an assessment of the performance of the construction product carried out on the basis of testing (including sampling), calculation, tabulated values or descriptive documentation of the product;
 - (ii) initial inspection of the manufacturing plant and of factory production control;
 - (iii) continuous surveillance, assessment and evaluation of factory production control.

4.2 AVCP for construction products for which a European Technical Assessment has been issued

Notified bodies undertaking tasks under System 1 shall consider the European Technical Assessment issued for the construction product in question as the assessment of the performance of that product. Notified bodies shall therefore not undertake the tasks referred to in point 4.1 (b)(i).

5 Technical details necessary for the implementation of the AVCP system, as provided for in the applicable European Assessment Document

5.1 Tasks for the manufacturer

5.1.1 Factory production control

In the manufacturing plant the manufacturer shall establish and continuously maintain a factory production control. All procedures and specification adopted by the manufacturer shall be documented in a systematic manner. The factory production control shall ensure the constancy of performances of RadiusHolz with regard to the essential characteristics.

The manufacturer shall only use raw materials supplied with the relevant inspection documents as laid down in the control plan. The incoming raw materials shall be subject to controls by the manufacturer before acceptance. Check of incoming materials shall include control of inspection documents presented by the manufacturer of the raw materials.

The frequencies of controls conducted during manufacturing and on the assembled product are defined by taking account of the manufacturing process of the product and are laid down in the control plan.

⁵ The prescribed test plan has been deposited with Österreichisches Institut für Bautechnik and is handed over only to the notified product certification body involved in the procedure for the assessment and verification of constancy of performance. The prescribed test plan is also referred to as control plan.

Table 3: Product characteristics of the solid wood slab

BR	Essential characteristic	Method of verification	Level / Class / Description	
1	Mechanical resistance and stability			
	1. Mechanical actions perpendicular to cross laminated timber			
	Strength class of boards	EN 338	see Table 2	
	Modulus of elasticity		curved	plane
	– parallel to the grain of the boards $E_{0, mean}$	I_{eff} , Annex 3 EAD 130005-00-0304, 2.2.1.1	10 200 MPa ¹⁾	11 500 MPa
	– perpendicular to the grain of the boards $E_{90, mean}$	EN 338	370 MPa	
	Shear modulus			
	– parallel to the grain of the boards $G_{090, mean}$	EN 338	690 MPa	
	– perpendicular to the grain of the boards (rolling shear modulus) $G_{9090, mean}$	EAD 130005-00-0304, 2.2.1.1	50 MPa	
	Bending strength			
– parallel to the grain of the boards $f_{m, k}$	W_{eff} , Annex 3 EAD 130005-00-0304, 2.2.1.1	$1/k_{sys} \cdot 26.4 \text{ MPa}^{2)}$		
Tensile strength				
– perpendicular to the grain of the boards $f_{t, 90, k}$	EN 338, reduced	0.15 MPa		
Compressive strength				
– perpendicular to the grain of the boards $f_{c, 90, k}$	EN 338	2.5 MPa		
Shear strength				
– parallel to the grain of the boards $f_{v, 090, k}$	A_{gross} , Annex 3 EAD 130005-00-0304, 2.2.1.3	2.3 MPa		
– perpendicular to the grain of the boards (rolling shear strength) $f_{v, 9090, k}$		1.10 MPa		

NOTE 1) 1 MPa = 1 N/mm²

2) $k_{sys} = \max \left\{ \begin{matrix} 1,1 - 0,025 \cdot n \\ 1 \end{matrix} \right.$ $n \dots$ number of boards within cover layer

RadiusHolz

Annex 2

Characteristic data of cross laminated timber

of European Technical Assessment
ETA-16/0055 of 16.10.2020

BR	Essential characteristic	Method of verification	Level / Class / Description	
1	Mechanical resistance and stability			
	2. Mechanical actions in plane of cross laminated timber			
	Strength class of boards	EN 338	see Table 2	
	Modulus of elasticity	$A_{net}, I_{net}, \text{Annex 3}$ EAD 130005-00-0304, 2.2.1.1	curved	plane
	– parallel to the grain of the boards $E_{0, mean}$		10 200 MPa	11 500 MPa
	Shear modulus	$A_{net}, \text{Annex 3}$ EAD 130005-00-0304, 2.2.1.3	curved	plane
	– parallel to the grain of the boards $G_{090, mean}$		570 MPa	690 MPa
	Bending strength	$W_{net}, \text{Annex 3}$ EAD 130005-00-0304, 2.2.1.1	24 MPa	
	– parallel to the grain of the boards $f_{m, k}$			
	Tensile strength	EN 338	14 MPa	
	– parallel to the grain of the boards $f_{t, 0, k}$			
	Compressive strength	EN 338	21 MPa	
	– parallel to the grain of the boards $f_{c, 0, k}$			
Shear strength	$A_{net}, \text{Annex 3}$ EAD 130005-00-0304, 2.2.1.3	2.7 MPa		
– parallel to the grain of the boards $f_{v, 090, k}$				
3. Other mechanical actions				
Creep and duration of load	k_{mod} and k_{def} according to EN 1995-1-1 for glued laminated timber			
Dimensional stability Moisture content during service shall not change to such an extent that adverse deformation will occur.				
Fasteners	EN 1995-1-1, the direction of grain of the cover layer shall be taken as reference			

RadiusHolz

Annex 2

Characteristic data of cross laminated timber

of European Technical Assessment
ETA-16/0055 of 16.10.2020

Mechanical actions perpendicular to plane and in plane of cross laminated timber

General

Due to the perpendicular orientation of the boards, cross laminated timber is able to transfer loads in all directions according to its condition of support. For cross laminated timber multi-axle stressed in both principal directions, different stiffness for the two principal directions shall be considered.

For calculation of the characteristic values of the cross-section, only boards which are oriented in direction of the mechanical action may be employed.

For design of cross laminated timber according to EN 1995-1-1, characteristic strength and stiffness of solid wood according to Annex 2 shall be taken.

For curved elements the verification of the bending stress as well as interaction of transverse stress and shear shall be performed according to EN 1995-1-1, 6.4.3.

Mechanical actions perpendicular to cross laminated timber

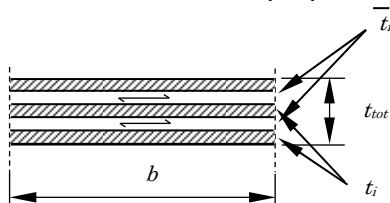

Where

t_i Thickness of board layers in direction of mechanical actions

\bar{t}_i Thickness of board layers perpendicular to direction of mechanical actions

The bending stiffness is specified in relation to the effective moment of inertia I_{eff} .

The calculation of the effective moment of inertia and therewith of the effective bending stiffness is according to EN 1995-1-1.

For I_{eff} see clause 9.1.3 and Annex B of EN 1995-1-1.

The term $\frac{s_i}{K_i}$ of EN 1995-1-1 should be substituted by $\frac{\bar{t}_i}{G_{9090} \cdot b}$.

$$I_i = \frac{b \cdot t_i^3}{12}$$

$$W_{eff} = \frac{2 \cdot I_{eff}}{t_{tot}}$$

$$A_i = b \cdot t_i$$

$$h_{tot} = \sum_i (t_i + \bar{t}_i)$$

$$\tau_{v,d} = \frac{1.5 \cdot V_d}{A_{gross}}$$

$$A_{gross} = b \cdot t_{tot}$$

Where

I moment of inertia

I_{eff} effective moment of inertia

s spacing of fasteners according to EN 1995-1-1 (not relevant for solid wood slab)

K slip modulus according to EN 1995-1-1 (not relevant for solid wood slab)

G_{9090} shear modulus of the board perpendicular to grain (rolling shear modulus); $G_{9090} = 50$ MPa

b width of the member of cross laminated timber

RadiusHolz	Annex 3
Design considerations for cross laminated timber	of European Technical Assessment ETA-16/0055 of 16.10.2020

Mechanical actions in plane of the solid wood slab

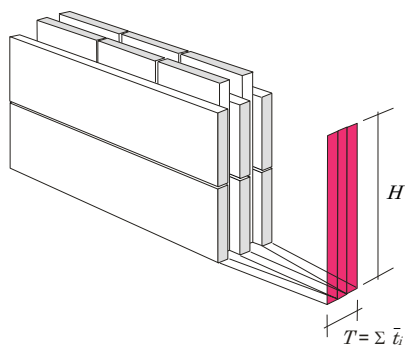

Where

$H \leq 400$ mm

t_i Thickness of board layers in direction of mechanical actions

\bar{t}_i Thickness of board layers perpendicular to direction of mechanical actions

V Shear force

Under the terms of the technical beam theory, the following equations may be used.

Moment of inertia

$$I_{net} = \frac{T \cdot H^3}{12}$$

Shear stress

$$\tau_{v,d} = \text{Maximum} \begin{cases} \frac{3}{2} \cdot \frac{V_d}{A_{x,net}} \\ \frac{3}{2} \cdot \frac{V_d}{A_{z,net}} \end{cases}$$

Section modulus

$$W_{net} = \frac{T \cdot H^2}{6}$$

$$A_{x,net} = H \cdot \sum_i \bar{t}_i$$

$$A_{z,net} = H \cdot \sum_i t_i$$

RadiusHolz

Annex 3

Design considerations for cross laminated timber

of European Technical Assessment
 ETA-16/0055 of 16.10.2020

